

Atlas Copco Portable air compressors

XAS 756 – XAMS 600 – XAHS 500



Atlas Copco



The face of interaction

Principal data

Compressor				
Type		XAS 756	XAMS 606	XAHS 500
Normal effective working pressure	bar(e)	7.0	8.6	12
	psig	102	125	175
Actual free air delivery guaranteed acc. to ISO 1217 ed. 3 1996 annex D	cu.ft/min	756	619	500
Sound pressure level acc. ISO 2151 at 7 m	dB(A)	76	76	76
Oil capacity	L	49	49	49
	US gal	12	12	12
Max. ambient temperature	C	50	50	50
	F	122	122	122
Engine		Caterpillar 3126B	3126B	3126B
Number of cylinders		6	6	6
Full load speed	r/min	2500	2500	2500
Output at rated speed	HP	200	200	200
Capacity of fuel tank	US gal	76	76	76

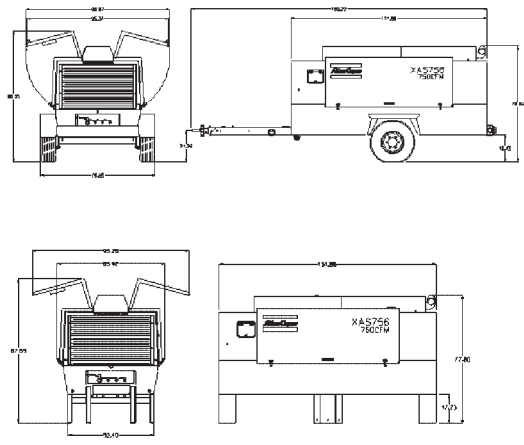

		A	B	C	
Dry weight	XAHS 500	kg	2500	2180	2160
		lbs	5513	4807	4762
	XAMS 600	kg	2500	2180	2160
		lbs	5513	4807	4762
	XAS 756	kg	2500	2180	2160
		lbs	5513	4807	4762
Wet Weight	XAHS 500	kg	2900	2580	2560
		lbs	6395	5699	5644
	XAMS 600	kg	2900	2580	2560
		lbs	6395	5699	5644
	XAS 756	kg	2900	2580	2560
		lbs	6395	5699	5644

Danger: Compressed air should never be supplied as breathing air unless air is properly purified for breathing. Atlas Copco assumes no responsibility or liability related to the purchaser's/user's use of an Atlas Copco compressor as part of a breathing air system.

The information contained herein is general in nature and is not intended for specific construction, installation or application purposes. Technical specifications and pricing are subject to change without notice.



Member:

